

 **Vogelsitze**[®]



LS 60

LS 60
Coach

LS60

Der Fahrgastsitz des 21. Jahrhunderts

Bestechende Eleganz, höchster Komfort und perfekte Sicherheit in innovativem Design und modernster Technik. Die Ergonomie des Sitzes, seine Linienführung und Polsterung bieten höchsten Komfort auf allen Strecken.

The 21st Century Passenger Seat

Sheer elegance, top comfort and absolute safety combined with innovative design and state-of-the-art technology. The seats ergonomic design, its elegant lines and upholstery ensure maximum comfort, wherever your journey takes you.

Le siège passager du 21ème siècle

Elégance éblouissante, confort exceptionnel et sécurité absolue en plus d'un design novateur et d'une technique des plus modernes. L'érgonomie du siège, son dossier galbé et son rembourrage offrent un confort maximal sur tous les trajets.

El asiento del acompañante del siglo XXI

una elegancia seductora, suprema comodidad y perfecta seguridad combinadas con un diseño innovador y la técnica más moderna. La forma ergonómica del asiento, sus líneas y su acolchado ofrecen la más alta comodidad en todos los trayectos.



SAFER



CLEANER



LIGHTER



SMARTER

Core-Struktur – Die leichtere Lösung

Reise-/Überlandbusse

Gewichtersparnis im Premium- und Standardsegment

- weniger CO₂-Ausstoß
- geringerer Kraftstoffverbrauch

Vereinheitlichte Struktur für alle Reise- und Überlandbus-Sitze

- nur eine benötigte Fahrzeughomologation für sechs verschiedene Sitztypen nach ECE R 14

Innovation

- optimierter Sitzkomfort durch neue ergonomische Ausformung

optional:

- Vorrichtungen zur Nutzung Ihrer mobilen Medien

Core-Structure – The lighter solution

Coach/Intercity Seats

Weight reduction in the premium and standard segments

- reduced CO₂ emission
- lower fuel consumption > fuel cost savings

Common structure for all coach and intercity seats

- only one homologation/bus needed for all six different seat types according to ECE R 14

Innovation

- optimized seating comfort due to a new ergonomical shape

optional:

- ready for your mobile connectivity

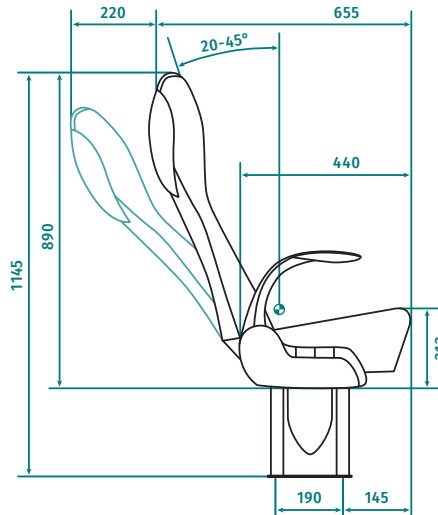
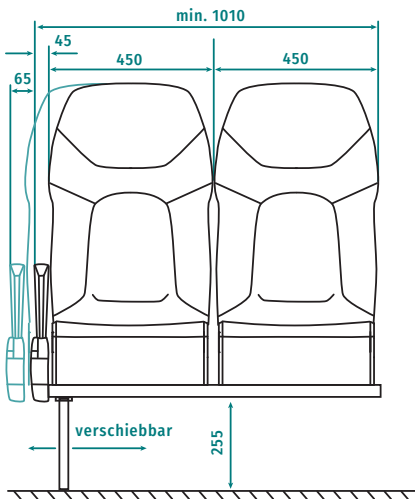

Hochfest
Fix back rest
Dossier fixe
Respaldo fijo



Rückwärtsverstellung
Seat back reclining mechanism
Inclinaison du dossier
Ajuste hacia atras



Seitwärtsverstellung
Sideway movement
Décalage latéral
Ajuste lateral



ISOFIX - Kindersitzbefestigung
ISOFIX - child seat fastening
ISOFIX - fixation pour siège enfant
ISOFIX - fijación del asiento del niño



2 Punkt- u. 3 Punktgurtsystem
2 point and 3 point belt
Ceintures 2 et 3 points
Cinturones de 2 y 3 Puntos



USB-Anschluss
USB port
Port USB
Puerto USB



Steckdose 220V
Power outlet 220V
Socle 220V
Enchufe 220V



F-Variante
F-variation
Variante F
Variante F

Wurzelholzbaum-Dekor
WNB (rootwood)
WNB (bois)
WNB (madera)



Carbon-Dekor
Carbon
Carbone
Carbono



Perlmausgrau (ähn. RAL 7048)
Pearl mouse grey (sim. RAL 7048)
Gris perlé (sim. RAL 7048)
Gris perla (sim. RAL 7048)



Armauflege
Decor for armrest
Décor de bras
Decoraciones de brazos

Haltegriff, ein- oder beidseitig
Grab handle, unilateral or bilateral
Poignée, unilatéral ou bilatéral
Asidero, unilateral o bilateral



USB-Anschluss
USB port
Port USB
Puerto USB



Absenkbare Armlehne
Fold-down armrest
Accoudoir escamotable
Apoyabrazos abatible



Beinauflege ausziehbar
Adaptable leg rest
Repose-jambe réglable
Reposapiernas adaptable



Pompadour-Tasche
Bag
Aumônière
Bolsillo Pompadour



Zeitungsnetz
Document net
Porte document
Revistero



Klapptisch
Tray table
Tablette
Mesa



Freitragender Tisch
Self-supportive tray table
Tablette type avion
Mesa independiente

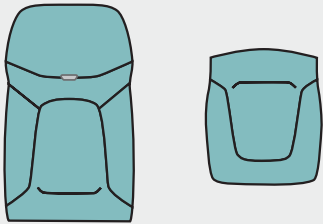
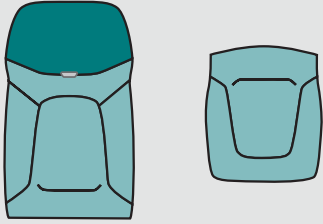
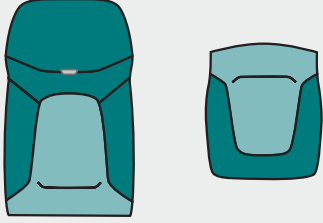
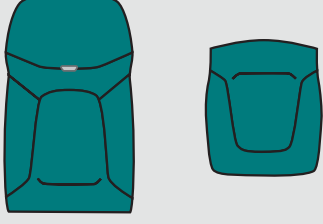

optionale Polsterung | optional upholstery | garnissage optionnel | acolchado opcional

Darstellung graph	Bezeichnung designation	Beschreibung description	Option option
	Standard	Ausführung in Stoff <i>fabric design</i>	<ul style="list-style-type: none"> • Keder <i>piping</i> • Doppelsteppnaht <i>double quilting seam</i>
	Plus	Zusätzlich abgesetzter Kopfeinsatz <i>Additional contrasting headrest insert</i>	<ul style="list-style-type: none"> • Ambassador: hochwertige Doppelpolsterung <i>Additional Ambassador upholstery</i>
	Prestige	Zusätzlich abgesetzter Kopfeinsatz und Seitenteile <i>Additional contrasting headrest insert and side parts</i>	<ul style="list-style-type: none"> • Deluxe: zusätzlich 10 mm Schaumpolsterung <i>Additional Deluxe 10 mm upholstery</i>
	Executive	Ausführung in Vollleder <i>leather design</i>	

Kontakt | contact | contacter | contacto

Vogelsitze GmbH

Kleinsteinbacher Straße 44
D - 76228 Karlsruhe
Germany

Phone | Telefon: +49 721 4702 0
Fax | Telefax: +49 721 4702 2500
E-Mail: info@vogelsitze.com