

*vogelsitze*<sup>®</sup>



# Primus

**Primus**  
City | Intercity

## Primus

### Individuelle Kombinationsmöglichkeiten

Primus kann mit 2- und 3-Punkt Sicherheits-Gurten ausgestattet werden. Optionale Rückenabdeckschalen schützen wirkungsvoll Sitzrücken und Kissen. Primus entspricht als Überlandsitz allen Anforderungen dieser Klasse. Die Sitzplatzbreite 420 mm erlaubt Bestuhlungen vom Kleinbus bis hin zum großen Intercitybus. Modularität, Vielseitigkeit und Robustheit machen Primus zum idealen Überlandsitz. Die Vielfältigkeit vom schmalen Primus macht ihn zum Allrounder für Midibusse. Primus kann auch als Beifahrersitz verwendet werden.

### Individual Combinations

Primus can be equipped with 2- and 3-point safety belts. Optional seat back panels provide best protection for the upholstery parts. As an intercity seat Primus responds to all requirements of this class. The seat width 420 mm enables seat arrangements from minibus to intercity buses. Modularity, variety and rigidity make Primus the ideal intercity bus seat. Primus is an allround seat for midibuses, also available as guide seat.

### Combinaisons Individualisées

Au choix Primus peut être équipé de ceintures de sécurité 2 ou 3 points. La coque arrière optionnelle protège efficacement le dossier et l'assise du siège. Comme siège interurbain Primus répond à toutes les réglementations de cette catégorie. La largeur de 420 mm permet l'équipement en sièges du minibus jusqu'au bus interurbain. Sa modularité, sa diversité et sa robustesse font de Primus le siège interurbain par excellence.

### Combinaciones Individuales

Primus puede montar cinturones de 2 ó 3 pts. Carcasa de plástico tracera optional, abrigo eficaz, Respaldo y Cojín. El Primus corresponde con anchura 420 mm, montaje de minibuses asta autobuses interurbanos. Modularidad, la variedad y la rigidez hacen de Primus el asiento ideal para autobuses interurbanos.



# Primus

City | Intercity

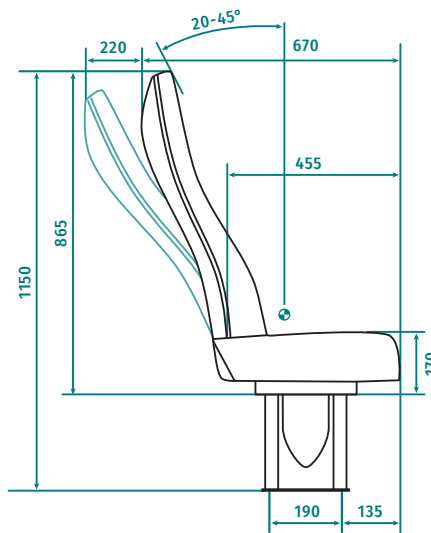
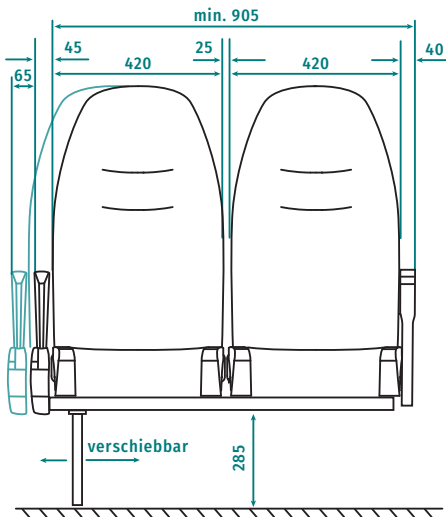

Hochfest  
Fix back rest  
Dossier fixe  
Respaldo fijo



Rückwärtsverstellung  
Seat back reclining mechanism  
Inclinaison du dossier  
Ajuste hacia atras



Seitwärtsverstellung  
Sideway movement  
Décalage latéral  
Ajuste lateral



2 Punkt- u. 3 Punktgurtsystem  
2 point and 3 point belt  
Ceintures 2 et 3 points  
Cinturones de 2 y 3 Puntos

ISOFIX

ISOFIX - Kindersitzbefestigung  
ISOFIX - child seat fastening  
ISOFIX - fixation pour siège enfant  
ISOFIX - fijación del asiento del niño



F-Variante  
F-variation  
Variante F  
Variante F



Haltegriff, ein- oder beidseitig  
Grab handle, unilateral or bilateral  
Poignée, unilatéral ou bilatéral  
Asidero, unilateral o bilateral



Bogengriff  
Grab handle  
Poignée  
Asidero

Wurzelholzbaum-Dekor  
WNB (rootwood)  
WNB (bois)  
WNB (madera)



Carbon-Dekor  
Carbon  
Carbone  
Carbono



Perlmausgrau (ähn. RAL 7048)  
Pearl mouse grey (sim. RAL 7048)  
Gris perlé (sim. RAL 7048)  
Gris perla (sim. RAL 7048)



Armauflage  
Decor for armrest  
Décor de bras  
Decoraciones de brazos

Pompadour-Tasche  
Bag  
Aumônière  
Bolsillo Pompadour



Zeitungsnetz  
Document net  
Porte document  
Revistero



Absenkbare Armlehne  
Fold-down armrest  
Accoudoir escamotable  
Apoyabrazos abatible



Klapptisch  
Tray table  
Tablette  
Mesa



Abweisbügel  
Security bar  
Câle hanche  
Quita sustos



Winkelabdeckung  
Seat angle cover  
Cache latéral  
Ángulo de cobertura

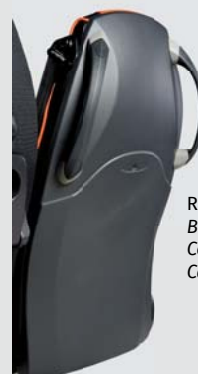

Rückenabdeckschale  
Back panel  
Coque arrière  
Carcasa de plástico

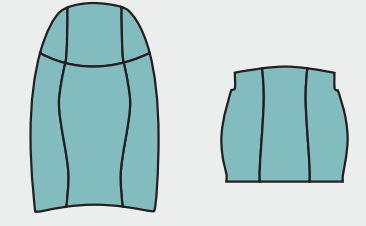
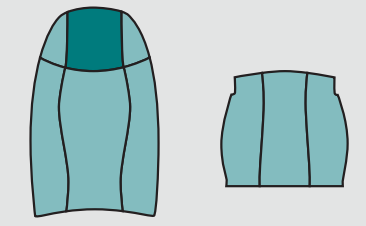
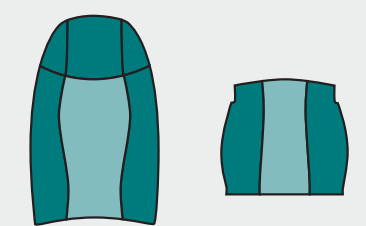
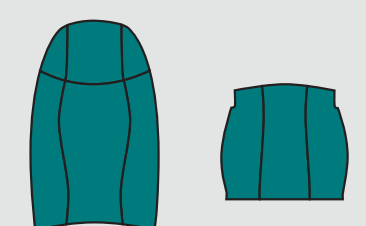

optionale Polsterung | optional upholstery | garnissage optionnel | acolchado opcional

Darstellung graph	Bezeichnung designation	Beschreibung description	Option option
	Standard	Ausführung in Stoff <i>fabric design</i>	<ul style="list-style-type: none"> <li>• Keder <i>pipng</i></li> <li>• Doppelsteppnaht <i>double quilting seam</i></li> </ul>
	Plus	Zusätzlich abgesetzter Kopfeinsatz <i>Additional contrasting headrest insert</i>	<ul style="list-style-type: none"> <li>• Ambassador: hochwertige Doppelpolsterung <i>Additional Ambassador upholstery</i></li> </ul>
	Prestige	Zusätzlich abgesetzter Kopfeinsatz und Seitenteile <i>Additional contrasting headrest insert and side parts</i>	<ul style="list-style-type: none"> <li>• Deluxe: zusätzlich 10 mm Schaumpolsterung <i>Additional Deluxe 10 mm upholstery</i></li> </ul>
	Executive	Ausführung in Vollleder <i>leather design</i>	

Kontakt | contact | contacter | contacto

## Vogelsitze GmbH

Kleinsteinbacher Straße 44  
D-76228 Karlsruhe  
Germany

Phone | Telefon: +49 721 4702 0  
Fax | Telefax: +49 721 4702 2500  
E-Mail: info@vogelsitze.com