

vogelsitze[®]



Pino

Pino
City | Intercity

Pino

Pino steht für höchste Produktinnovation

Gerignes Gewicht bei hoher Festigkeit dank intelligenter Konstruktion und Werkstoffauswahl. Die „Welle mit Funktion“ bringt perfekten Sitzkomfort, optimalen Seitenhalt, Luftzirkulation im Rückenbereich.

Pino stands for highest product innovation

Low weight and high strength thanks to intelligent design and material selection.

The 'functional wave' for perfect comfort, optimum side support, and air circulation at the back.

Pino à la pointe du progrès

Une vague qui offre tout à la fois confort d'assise et appui latéral. Un poids plume obtenu grâce à un design intelligent et le choix de matériaux sélectionnés pour ce critère.

Pino simboliza la mejor innovación de producto

Peso bajo con resistencia alta, gracias á los materiales y construcciones inteligente. El diseño en forma „de ola“ hace la butaca PINO confortable y respirable para el pasajero con un óptimo soporte lateral.



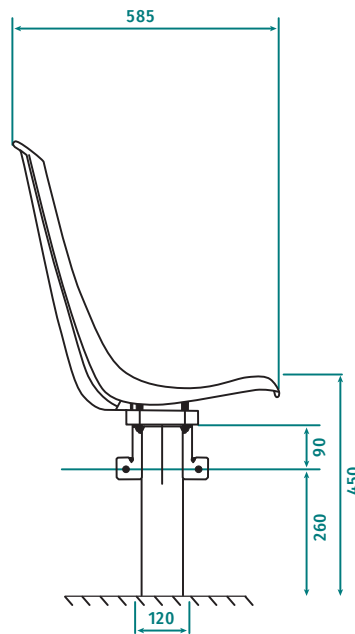
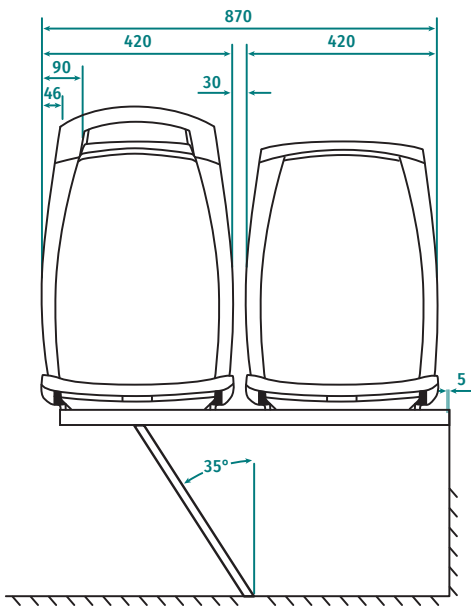

1 1/2 1 1/2-Sitzer
1 1/2-Seater
Siège 1-1/2 places
Butaca de 1 plaza y media

2 2 Punktgurtsystem
2 point belt
Ceintures 2 points
Cinturones de 2 Puntos

Rückenabdeckschale
Back panel
Coque arrière
Carcasa plástica trasera



Stangenhalter
Pole holder
Porte colonne
Soporte de barra



Eck-Haltegriff
Corner grab handle
Poignée de circulation
Asidero lateral



Abweisbügel
Security bar
Câle hanche
Quita sustos



Wasserablauf
Water drain
L'écoulement de l'eau
Salida de agua



1 1/2 - Sitzer
1 1/2 - Seater
Siège 1-1/2 places
Butaca de 1 plaza y media



Klappsitz
Folding seat
Strapontin
Transportin



Ähnlich Similar Similaire Similar	RAL Design	RAL Design	RAL Design
		65 00	35 00
Sitzschale Front shell Coque de siège Carcasa	+	+	+
		Typ 030/300 only	Typ 030/300 only
Rückenabdeckschale Rear cover shell Coque arrière Carcasa trasera	+	+	+
Anbauteile Accessories Accessoires Accesorios		+	



Farbvarianten
Color variations

Sitzausführung | seat version | version de siège | versión butaca



PINO 100



PINO 200



PINO 300

Kontakt | contact | contacter | contacto

Vogelsitze GmbH

Kleinsteinbacher Straße 44
D-76228 Karlsruhe
Germany

Phone | Telefon: +49 721 4702 0
Fax | Telefax: +49 721 4702 2500
E-Mail: info@vogelsitze.com