

vogelsitze[®]



LS 30

LS 30
Coach

LS30

Kontur mit Komfort und Bewegungsfreiheit

Moderne Reisebus-Generationen brauchen modernes Interieur. LS30 erfüllt alle Aspekte, die Design und Funktion heute verlangen. Die neu entwickelte Rückenlinie in betont flacher Formgebung verschafft Schultern und Armen optimale Bewegungsfreiheit. LS30 bietet Platz, wo er benötigt wird!

Style with comfort and freedom of movement

For the latest coach generations, a modern interior is an obvious priority. LS30 satisfies the highest design and function requirements. The newly developed backrest with its novel flat design offers optimal freedom of movement for arms and shoulders. LS30 leaves space free where you need it!

Un contour allié au confort et à la liberté de mouvement

La génération moderne d'autocars nécessite un intérieur moderne. LS30 satisfait à tous les critères exigés aujourd'hui sur le plan du design et de la fonctionnalité. Liberté au niveau des épaules: Le galpe du nouveau dossier LS30 offre une liberté optimale de mouvement au niveau des épaules et des bras. LS30 propose de la place là où elle est requise!

Contorno cómodo y espacioso

Interiores modernos para autocaros modernos. LS30 ofrece todas las opciones de diseño y funcionalidad. Holgura para los hombros: Nueva línea de respaldos LS30 de diseño superplano que proporciona una libertad de movimiento óptima para hombros y brazos. LS30 crea espacios donde hacen falta!



SAFER



CLEANER



LIGHTER



SMARTER

Core-Struktur – Die leichtere Lösung

Reise-/Überlandbusse

Gewichtersparnis im Premium- und Standardsegment

- weniger CO₂-Ausstoß
- geringerer Kraftstoffverbrauch

Vereinheitlichte Struktur für alle Reise- und Überlandbus-Sitze

- nur eine benötigte Fahrzeughomologation für sechs verschiedene Sitztypen nach ECE R 14

Innovation

- optimierter Sitzkomfort durch neue ergonomische Ausformung

optional:

- Gurthöhenverstellung mit Rastfunktion
- Vorrichtungen zur Nutzung Ihrer mobilen Medien

Core-Structure – The lighter solution

Coach/Intercity Seats

Weight reduction in the premium and standard segments

- reduced CO₂ emission
- lower fuel consumption > fuel cost savings

Common structure for all coach and intercity seats

- only one homologation/bus needed for all six different seat types according to ECE R 14

Innovation

- optimized seating comfort due to a new ergonomical shape

optional:

- seat belt high adjuster with snap mechanism
- ready for your mobile connectivity

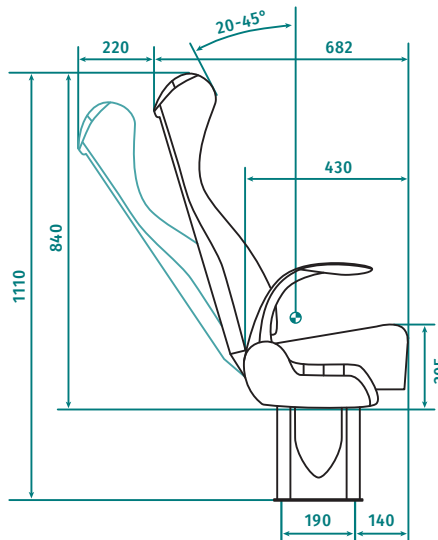
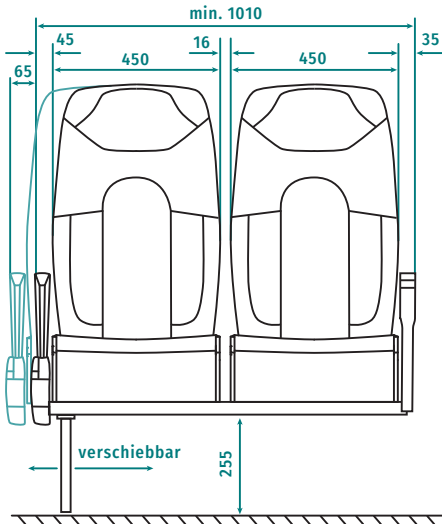

Hochfest
Fix back rest
Dossier fixe
Respaldo fijo



Rückwärtsverstellung
Seat back reclining mechanism
Inclinaison du dossier
Ajuste hacia atras



Seitwärtsverstellung
Sideway movement
Décalage latéral
Ajuste lateral



ISOFIX - Kindersitzbefestigung
ISOFIX - child seat fastening
ISOFIX - fixation pour siège enfant
ISOFIX - fijación del asiento del niño



2 Punkt- u. 3 Punktgurtsystem
2 point and 3 point belt
Ceintures 2 et 3 points
Cinturones de 2 y 3 Puntos



USB-Anschluss
USB port
Port USB
Puerto USB



Steckdose 220V
Power outlet 220V
Socle 220V
Enchufe 220V



F-Variante
F-variation
Variante F
Variante F



USB-Anschluss
USB port
Port USB
Puerto USB



Bogengriff
Grab handle
Poignée
Asidero

Wurzelnußbaum-Dekor
WNB (rootwood)
WNB (bois)
WNB (madera)



Carbon-Dekor
Carbon
Carbone
Carbono



Perlmausgrau (ähn. RAL 7048)
Pearl mouse grey (sim. RAL 7048)
Gris perlé (sim. RAL 7048)
Gris perla (sim. RAL 7048)



Armauflage
Decor for armrest
Décor de bras
Decoraciones de brazos

Pompadour-Tasche
Bag
Aumônière
Bolsillo Pompadour



Zeitungsnetz
Document net
Porte document
Revistero



Absenkbare Armlehne
Fold-down armrest
Accoudoir escamotable
Apoyabrazos abatible



Klapptisch
Tray table
Tablette
Mesa

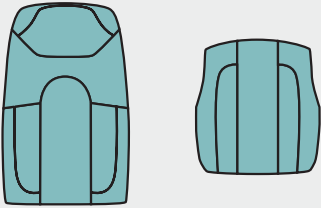
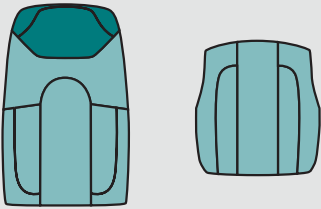
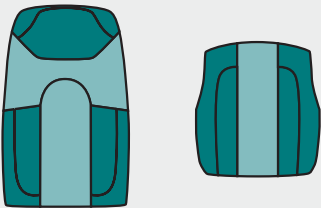
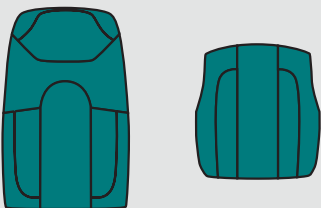

optionale Polsterung | optional upholstery | garnissage optionnel | acolchado opcional

Darstellung graph	Bezeichnung designation	Beschreibung description	Option option
	Standard	Ausführung in Stoff <i>fabric design</i>	<ul style="list-style-type: none"> • Keder <i>piping</i> • Doppelsteppnaht <i>double quilting seam</i>
	Plus	Zusätzlich abgesetzter Kopfeinsatz <i>Additional contrasting headrest insert</i>	<ul style="list-style-type: none"> • Ambassador: hochwertige Doppelpolsterung <i>Additional Ambassador upholstery</i>
	Prestige	Zusätzlich abgesetzter Kopfeinsatz und Seitenteile <i>Additional contrasting headrest insert and side parts</i>	<ul style="list-style-type: none"> • Deluxe: zusätzlich 10 mm Schaumpolsterung <i>Additional Deluxe 10 mm upholstery</i>
	Executive	Ausführung in Vollleder <i>leather design</i>	

Kontakt | contact | contacter | contacto

Vogelsitze GmbH

Kleinsteinbacher Straße 44
D-76228 Karlsruhe
Germany

Phone | Telefon: +49 721 4702 0
Fax | Telefax: +49 721 4702 2500
E-Mail: info@vogelsitze.com